



FUCHS
Fördertechnik AG

Your Specialist for Mega Yacht Cranes

High Performance • Advanced Technology • Latest Design



**We supply customized
material handling solutions.**

Worldwide.





FUCHS
Fördertechnik AG



AL

MARIN

TECH

reference in ports

BR htm

Service • Fachberatung
Tel. 0 40 3 1 23 45 67 89 0

Fragile. Very fragile.

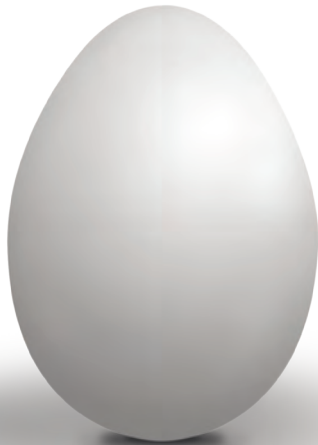

Just as if all loads were so delicate: that's what the special load cranes by FUCHS *Fördertechnik* AG are designed and built for. Which particularly benefits the mega yacht segment. Innovations, precision and functionality quickly turned FUCHS *Fördertechnik* AG, which was established by Klaus Husmann in 1962, into a globally successful company. The fulfilment of individual demands for perfect crane solutions is part of the business' everyday work.



FUCHS' top quality has come to dominate all areas where safety and reliability are the priority in transporting loads.



Handle with care



Board helicopter in the hangar



Sailing boat on deck



Supplies in the pantry



Tender on the deck



Life rafts next to the bulwark



Luxury tender in the garage

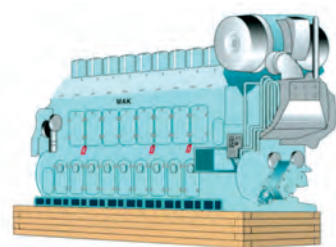

Crane for servicing the engine



Jet skis in the stern garage



Board motor cycle under deck

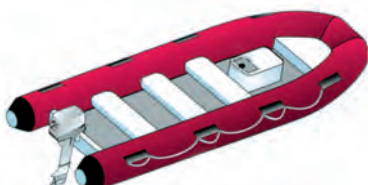

Rescue boat in the garage



Submarine in the submersible

Demanding solutions

Design meets precision and functionality. Crane systems in mega yachts must fulfil special demands. Each system constitutes an individual solution that delivers greatest effectiveness. The difficulties that FUCHS always skilfully deals with usually commence with the tight spaces made available for crane systems. Be it tender garages or helicopter hangars, FUCHS' specialists always come up with the right solution.



You can only move things if you move yourself

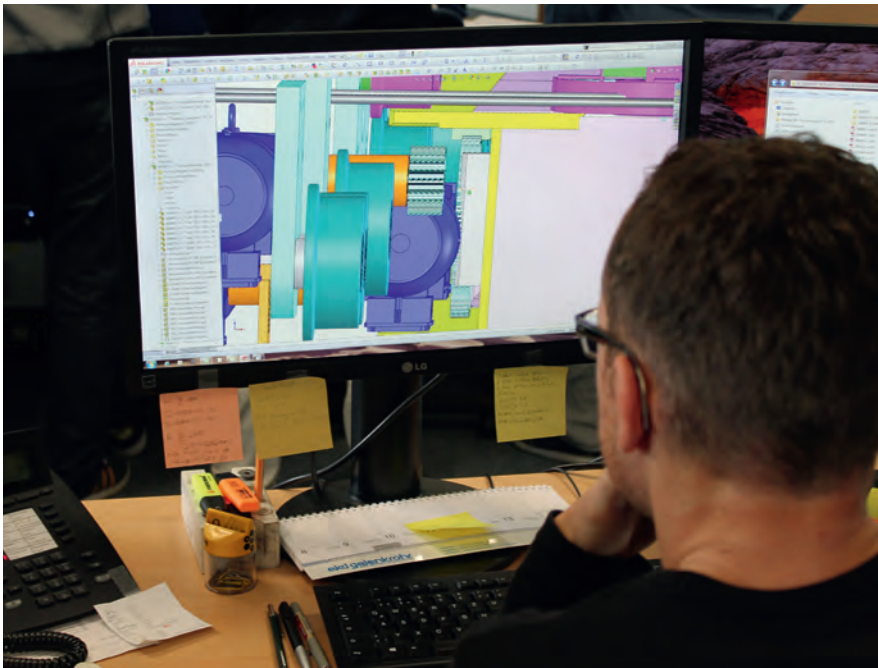

Designing with the help of powerful computers and up-to-date software but also classically on the drawing board when it's necessary to show interrelationships.



Rescue boat crane with large projection and freedom of movement: this stainless-steel gem has been designed for rapid deployment and only requires little space on board.

All-round-service down to the smallest detail

- Worldwide application of all conveyor and crane solutions
- Developments adapted to individual and demanding customer requests
- Ready-to-install completion of systems in accordance with requirement profiles
- Delivery and initial commissioning by experienced engineers
- Support during approval inspections by classification bodies
- Proper system maintenance and support during use

Working in a team ensures creativity in solutions to difficult tasks and guarantees on-going developments and a willingness to innovate. That's why FUCHS Fördertechnik AG is globally recognized as a successful specialist for individual crane solutions. From the start customers participate in planning meetings so that projects are planned jointly. This ensures that individual requests may be realized. The great technical know-how at FUCHS frequently opens up new and much better solution opportunities.



World market leader through precision



Dedicated staff guarantee high-quality products.



FUCHS also produces cranes' electrical systems in-house.



Special crane construction at FUCHS incorporates different assembly sections while combining top craftsmanship with tried-and-tested engineering and design skills. Top globally acclaimed products through highest precision and select materials. At FUCHS, the same high demands are made on staff and on suppliers in order to ensure an almost comprehensive manufacture of the products under a single roof. This is the only way to ensure maximum product quality and this is the only way to fulfil individual customer requirements at the highest level.



Under a single roof: production, quality control, equipment test.



Slewing jib crane for rescue boat and liferafts

In-house quality testing

Crane design at FUCHS *Fördertechnik* AG means that its systems are capable of handling particularly heavy loads. Their quality is ensured by strict quality management in accordance with DIN EN ISO 9001 - certified by DNV GL – as well as individual approvals by classification bodies appointed by customers.



Telescopic crane for tender boat



Deck crane for rescue boat



Deck crane for MOB

Hydraulically or electrically driven? Both types of system are available and employed according to customer requirements. The faster starting electric drives are frequently preferred. The desired concept is implemented just as precisely as the in-house production of important mechanical details for the systems. Highly polished: hook blocks for use on mega yachts.

Very strong

Stainless-steel individual Rescue boat crane for installation on deck.

High performance

Tender boat crane with telescopic arm for long distances



Tough. Heavy lifter.

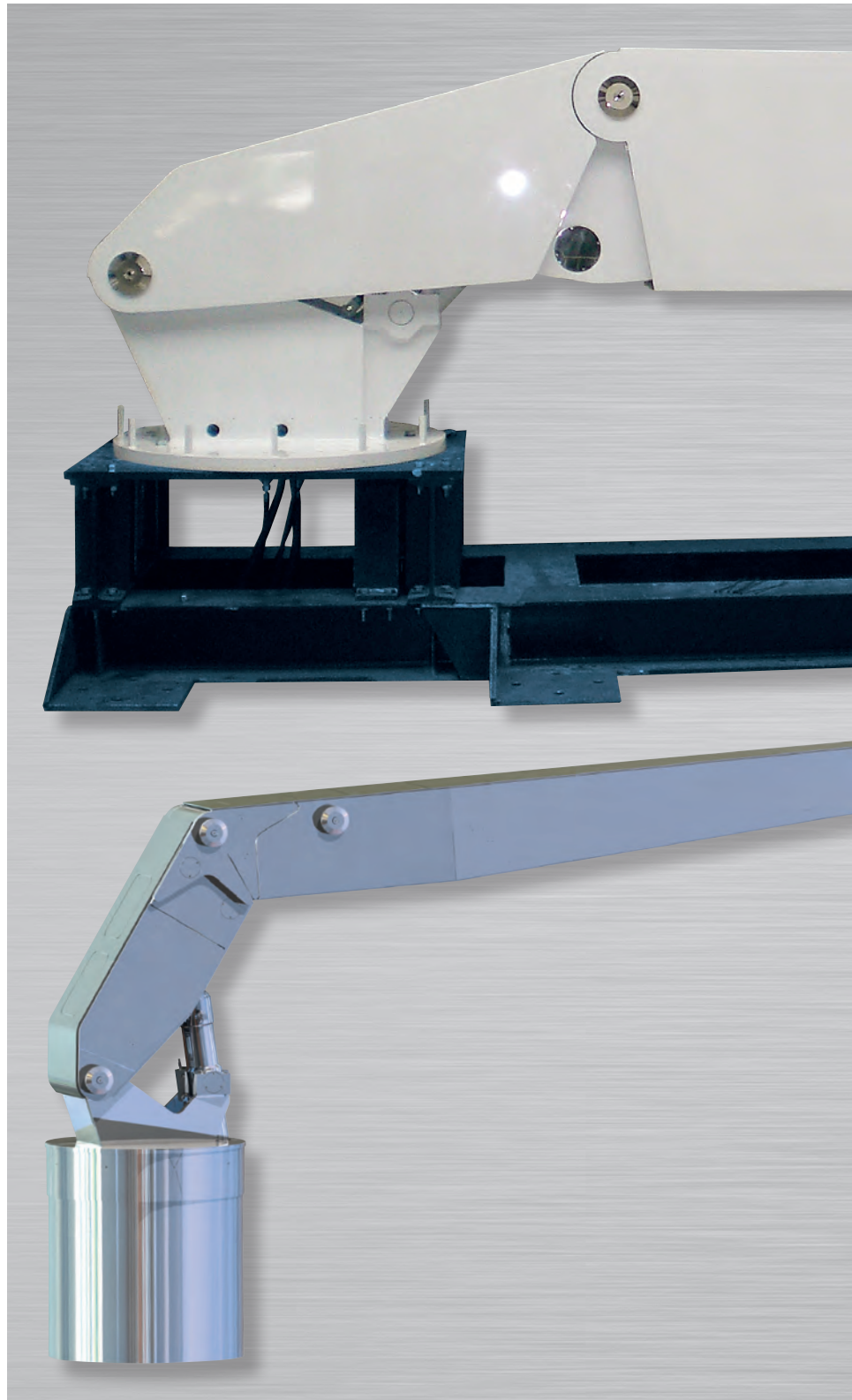

Stabil and flexible: Rescue boat crane with four-tonne load capacity (top) with two-tonne crane for variable applications (bottom).



Yacht owners demand highest individuality and reliability. And FUCHS always fulfils these requirements. Whether tender boats or jet skis have to be lowered, supplies brought on board or the main engine requires maintenance: all requirements for transporting loads from, on or within yachts are solved individually. Even the tightest of spaces is used in the best possible way without negatively impacting the systems' high performance capacities. Telescopic cranes with bearing capacities of up to 40 tonnes and supply cranes with more than 13 tonnes may be installed.



SWL 12,5t

Know-how and experience from navy and merchant shipping



Single girder overhead crane for hangar

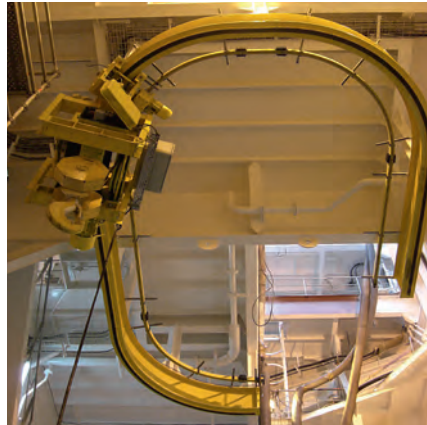

Radius going monorail trolley

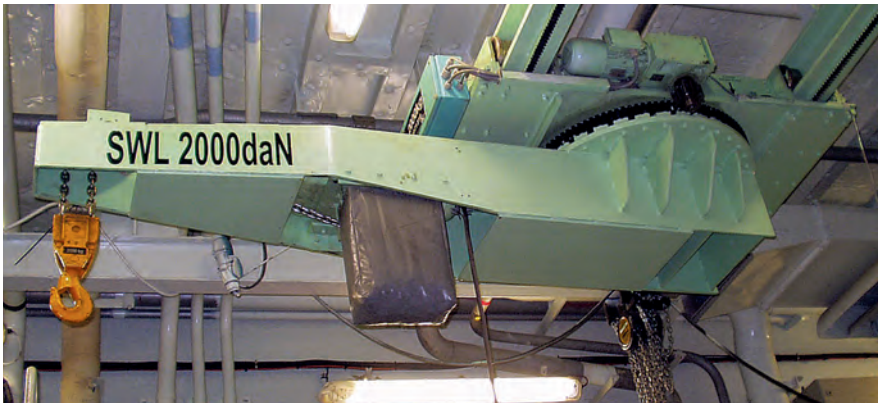

Overhead slewing jib crane for engine room

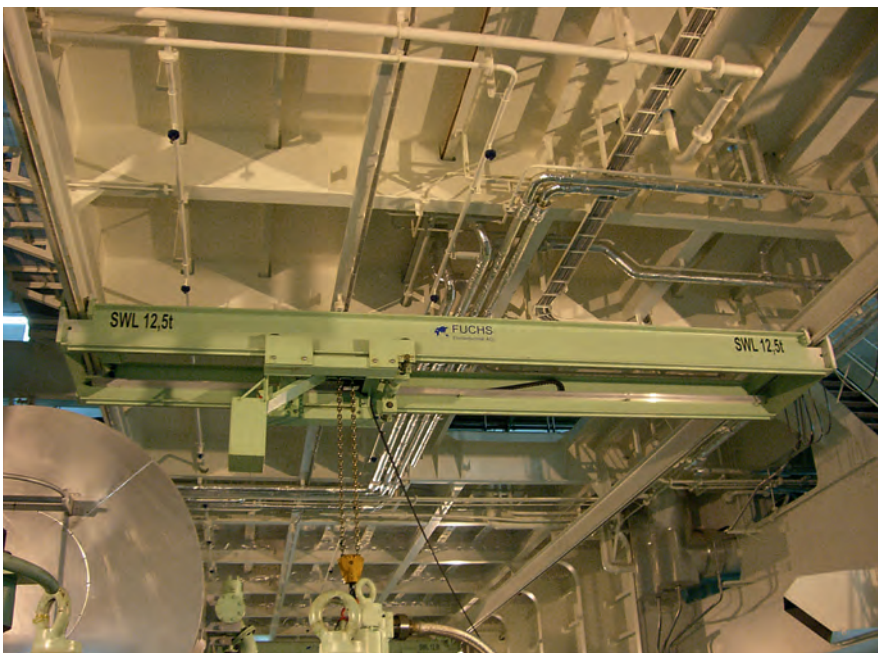

Double girder overhead crane with low headroom for engine room

Everything started at FUCHS with crane solutions for merchant shipping and the navy – solutions that to this day remain one of the pillars of the company's business. The robust cranes manufactured for continuous use in freight shipping and the special system is for navy applications constituted the basis for the high-quality individual crane systems used on mega yachts.



Elegant solutions for the beautiful "ladies"



Deck crane for rescue boat



Telescopic crane system for tender boat

FUCHS *Fördertechnik* AG is also known on the mega yacht segment for its practical and powerful systems as is demonstrated by the tender boat crane on the starboard side of "Martha Ann". The tender boat crane is simple to operate and was developed for long-term maintenance-free deployment and complies with all safety regulations applying to use on the high seas.





**The mega yacht sector needs the exclusive crane solutions
by FUCHS *Fördertechnik* AG.**

In this regard FUCHS can proudly state to have equipped four of the TOP 5 mega yachts of the world and moreover many other mega yachts with their cranes.

FUCHS has now opened an additional production hall and employed more specialist and committed staff for the new field of business building cranes for yachts.

In order to satisfy high demands, FUCHS now employs more than 70 technicians and engineers and is well equipped to deal with the demanding yacht tasks of the future.



FUCHS
Fördertechnik AG

Take Advantage of our Experience

FUCHS Fördertechnik AG

Am Knick 18
22113 Oststeinbek
Germany

Tel.: +49 40 7 100 10 0
Fax: +49 40 7 100 10 99

eMail: info@fuchs-cranes.de
www.fuchs-cranes.de

Your contacts at FUCHS Fördertechnik AG:

Cranes eMail: sales@fuchs-cranes.de

Services eMail: service@fuchs-cranes.de

Spare Parts eMail: spares@fuchs-cranes.de

